

MV Vane Type Particulate Scrubber

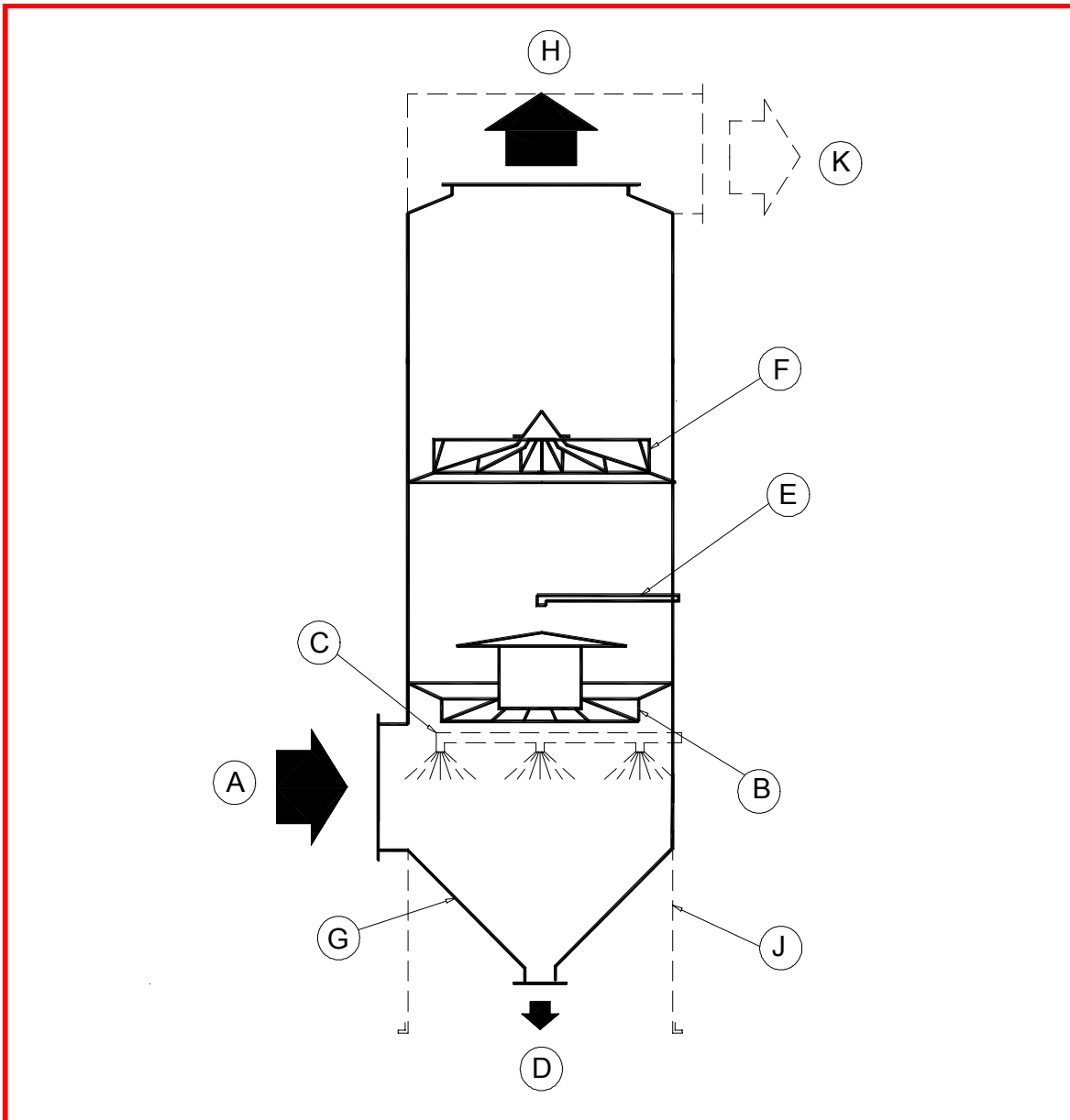

(A) Tangential Gas Inlet

(B) Intermediate Particulate Vane

(C) Inlet Pre-cooling Stage-
500°F

(D) Liquid Discharge

(E) Scrubbing Liquid Inlet

(F) Mist Eliminator Section

(G) Recycle Tank

(H) Clean Gas Outlet

(J) Optional Support Skirt

(K) Optional Gas Outlet